

PROFESSIONAL

# PROFESSIONAL

MIXING CONSOLE

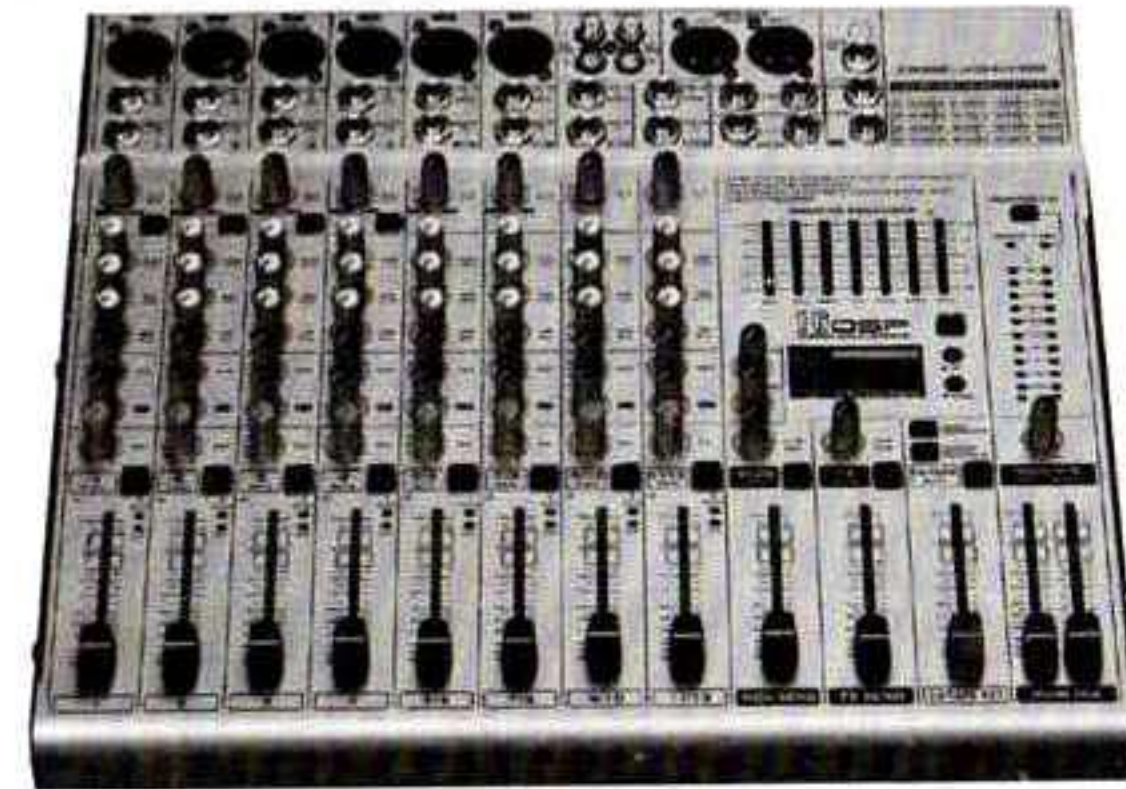

PROFESSIONAL  
MIXING CONSOLE

OPERATING MANUEL

ENGLISH

A. INPUT CHANNEL SECTION	1~2
B. STEREO CHANNEL SECTION	3
C. MIXER OUTPUT SECTION	4
D. POWER SECTION	5
E. INSTALLATION	5
F. HOW TO OPERATE	6
G. APPENDIX SPECIFICATIONS	7

## Ultra low noise 4 Channel Mic / Line Mixer

- ▲ 4 Mono Input Channels with gold plated XLRs and balanced Line Inputs
- ▲ Ultra-low noise discrete Mic Preamps with +48 V Phantom Power
- ▲ Extremely high headroom -offering more dynamic range
- ▲ Balanced Inputs for highest signal integrity
- ▲ Ultra-musical 2-band EQ on all channels
- ▲ Peak LEDs all Mono Channels
- ▲ 1 Aux Send per channel for external effects and monitoring
- ▲ Build in digital multi (16 DSP)
- ▲ Master Mix Output and rec output
- ▲ Highly accurate 10 segment Bargraph Meters
- ▲ Separate Master Mix Outputs

## SAFETY INSTRUCTIONS

**CAUTION:** To reduce the risk of electrical shock, do not remove the cover (or back). No user serviceable parts inside; refer to servicing to qualified personnel.

**WARNING:** To reduce the risk of fire or electrical shock, do not expose this appliance to rain or moisture.



This symbol, wherever it appears, alerts you to the presence of uninsulated dangerous voltage inside the enclosure voltage that may be sufficient to constitute a risk of shock.



This symbol, wherever it appears, alerts you to important operating and maintenance instructions in the accompanying literature. Read the manual.

## A. INPUT CHANNEL SECTION

### 1. BALANCE INPUT(MIC)

Electronically Balanced inputs acceptable at standard XLR male connector.

### 2. LINE INPUT

The unbalanced Mic input is provided for the use of unbalance Mic and is designed to accept an unbalanced high impedance input signal.

(This use for connection Deck, Turntable Keyboard etc...)

### 3. INSERT

The INSERT allows the signal to be taken out from the mixer through an external equipment such as a compressor and the back to continue the final mix output.

### 4. TRIM

This has a function which adjusts the input sensitivity of each channel in order to input the constant level of the signal.

### 5. LOW CUT

Slide down the slider-switch, insert the 18 dB per octave 75Hz low cut filter in the signal path. This low cut filter is useful on live vocals to reduce stage rumble or "popping" from microphones. It can also be used to cut off low frequency hum.

### 6. HIGH

Control the high frequency tone of each channel. Always set this control to the 12 o'clock position, but you can control the high frequency tone according to the speaker, the conditions of listening position and listener's taste. Clockwise rotation of the control increases level.

### 7. MID

This has a function which controls the middle frequency tone of each channel. Always set this control to the 12 o'clock position, but you can control the middle frequency tone according to the speaker, the conditions of listening position and listener's taste, clockwise rotation of the control increase the level, and vice versa.

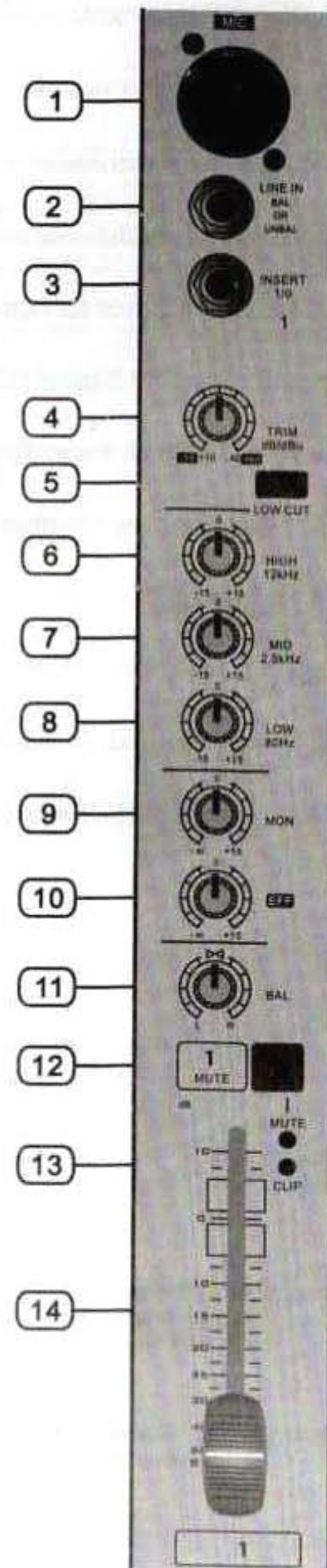

### 8. LOW

Control the low frequency tone of each channel. Always set this control to the 12 o'clock position, but you can control the low frequency tone according to the speaker, the conditions of listening position and listener's taste. Clockwise rotation of the control increases the level.

### 9. MON

This is normally derived after the EQ section and channel fader (PRE-FADER, POST-EQ), and is therefore unaffected by the fader position and routing status. This makes the send particularly suitable for foldback or monitor feeds which need to be controlled separately from the main P.A. mix. All pre-fader sends may be selected internally to be PER-FADER, PRE-EQ.

### 10. EFF

Use this control to set the effect level you want to achieve. The EFF control adjusts the input signal to give you a desired effect. If an external source is not in use, the EFF will function through the internal digital delay.

### 11. BAL

This has a function which distributes the signal level between left and right channels to make a stereo sound effect.

### 12. MUTE

All output from the channel are enabled when The MUTE switch released and muted when the switch is down.

### 13. CLIP

A red LED indicates a signal level at the insert return point, premaster fader, it illuminates at approximately 5dB below clipping.

### 14. CHANNEL FADER

This is function to adjust the volume of signal connection into each channel and adjust the volume of output together with with master fader. usually operating position is at the "0" mark, providing 4dB of gain above than point, it required.

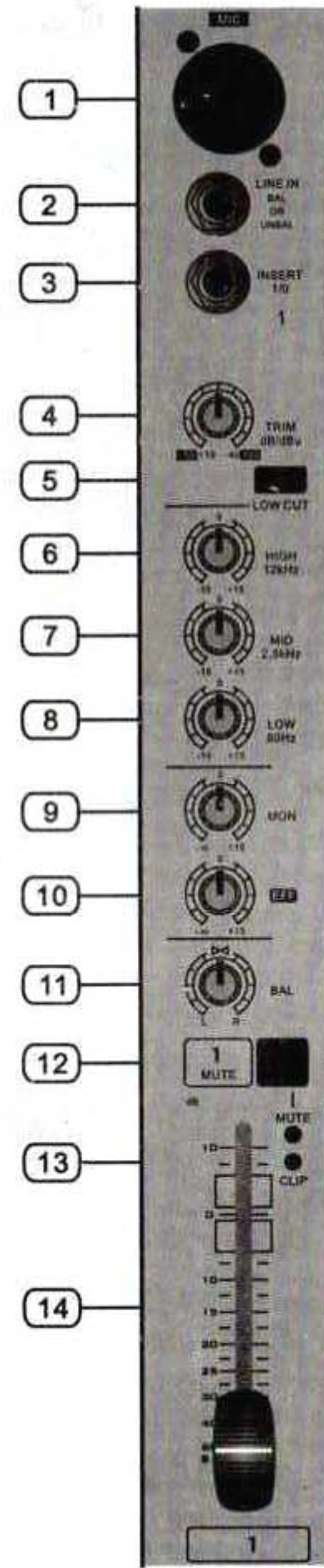

## B. STEREO CHANNEL SECTION

### 15. STEREO GRAPHIC EQUALIZER

2X7-band equalizer is provided for tone control over each frequency, and for precise high quality sound by final tone control.

### 16. EFF SEND

When you use STEREO board, you can adjust the sound volume of all kinds of effector outside.

### 17. REPEA

This is used for adjusting frequency of echo repeat, since too echo repeat may cause a nowl, please adjust frequency properly.

### 18. FX TO MON

You can use this control to insert an effects signal from the built-in effects processor to your monitor mix. Of course, to do this, your effects processor must first receive a signal, i.e. The FX controls in the channel strips must be turned up, and the FX SEND fader has to be open.

### 19. MON MUTE

If the MON MUTE switch is pressed, the monitor bus is muted, i.e. There is no signal at the MON SEND connector.

### 20. MON SEND

Connect the input of your monitor power amp or an active monitor system here to make the monitor mix audible to the musicians on the stage. The signal mix is created using the channels Mon controls.

### 21. FX TO MAIN

Use the FX TO MAIN control to feed the effects signal into the main mix. If the control is turned all the way to the left, no effects signal can be heard.

### 22. FX MUTE

If the FX MUTE switch is pressed, the effects channel is muted, i.e. no signal is present at the FX SEND connector and the effects processor no longer receiver an input signal.

### 23. FX SEND

The FX SEND fader determines the overall level of the effects bus Both external effects processors (Via the FX SEND connector) and the built-in processor only receive an input signal if this control is open.

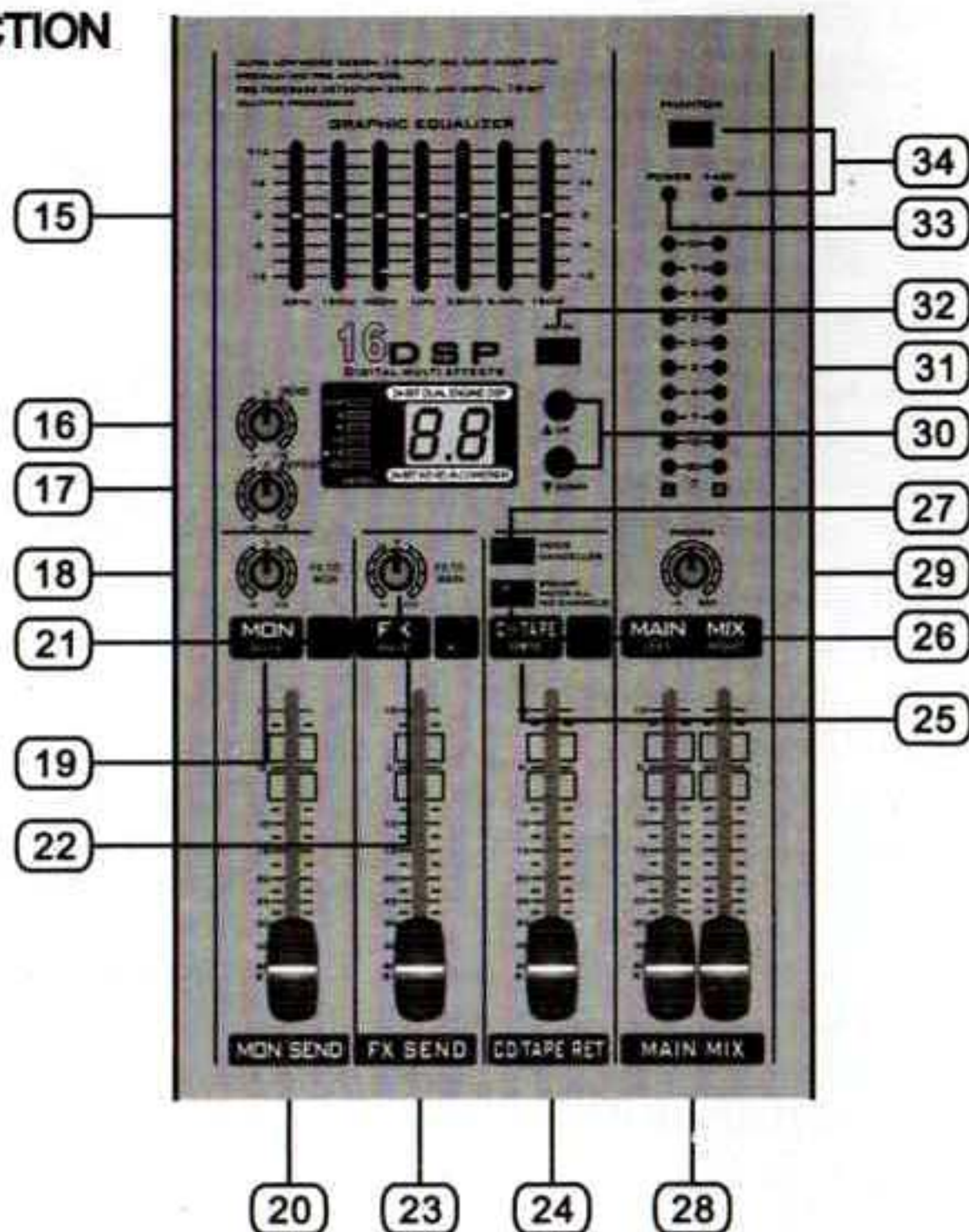

### 24. CD/TAPE RET

You can adjust the volume of TAPE in signal by this when connecting tape in.

### 25. CD/TAPE MUTE

Using this switch, the input signal from the CD/tape inputs is muted.

### 26. STANDBY

If the STANDBY switch is pressed, all input channels with a mic connector (XLR connector) are muted. During breaks or stage conversion, you can prevent noise from entering the sound system via the microphones, such noise can in the worst-case scenario even irreparably damage loudspeaker membranes. The cool thing about this is that the main mix faders can remain open, so that you can play music from a CD at the same time. Similarly, the faders for the muted channels can also remain in their position. To bring in other sound sources, you can use the CD/tape inputs, stereo input channels 9 to 12 and the aux return input.

### 27. VOICE CANCELLER

Here, you have a filter circuitry that lets you almost entirely remove the vocal portion of a recording. The filter is constructed in such a way that voice frequencies are targeted without majorly affecting the rest of the signal. Additionally, the filter seizes only the middle of the stereo image, exactly there the vocals are typically located.

Possible applications for the Voice canceller are obvious: you can very simply stage background music for Karaoke events. Of course, you can also do this at home or at your rehearsal room before you hit the stage. Singers with their own band can practice singing difficult parts using a complete playback from a tape player or a CD, thus minimizing rehearsal time.

### 28. OUTPUT MAIN FADER (LEFT/RIGHT)

This is a master fader for adjustment for volume of left/right output. Unity gain is the top their travel.

### 29. HEADPHONE LEVEL

This is a single volume control sends the level to be the headphones and main monitors.

### 30. DISPLAY

By pressing UP or DOWN under the display, you can select one of sixteen (16) sound effects which will be output through the master channel.

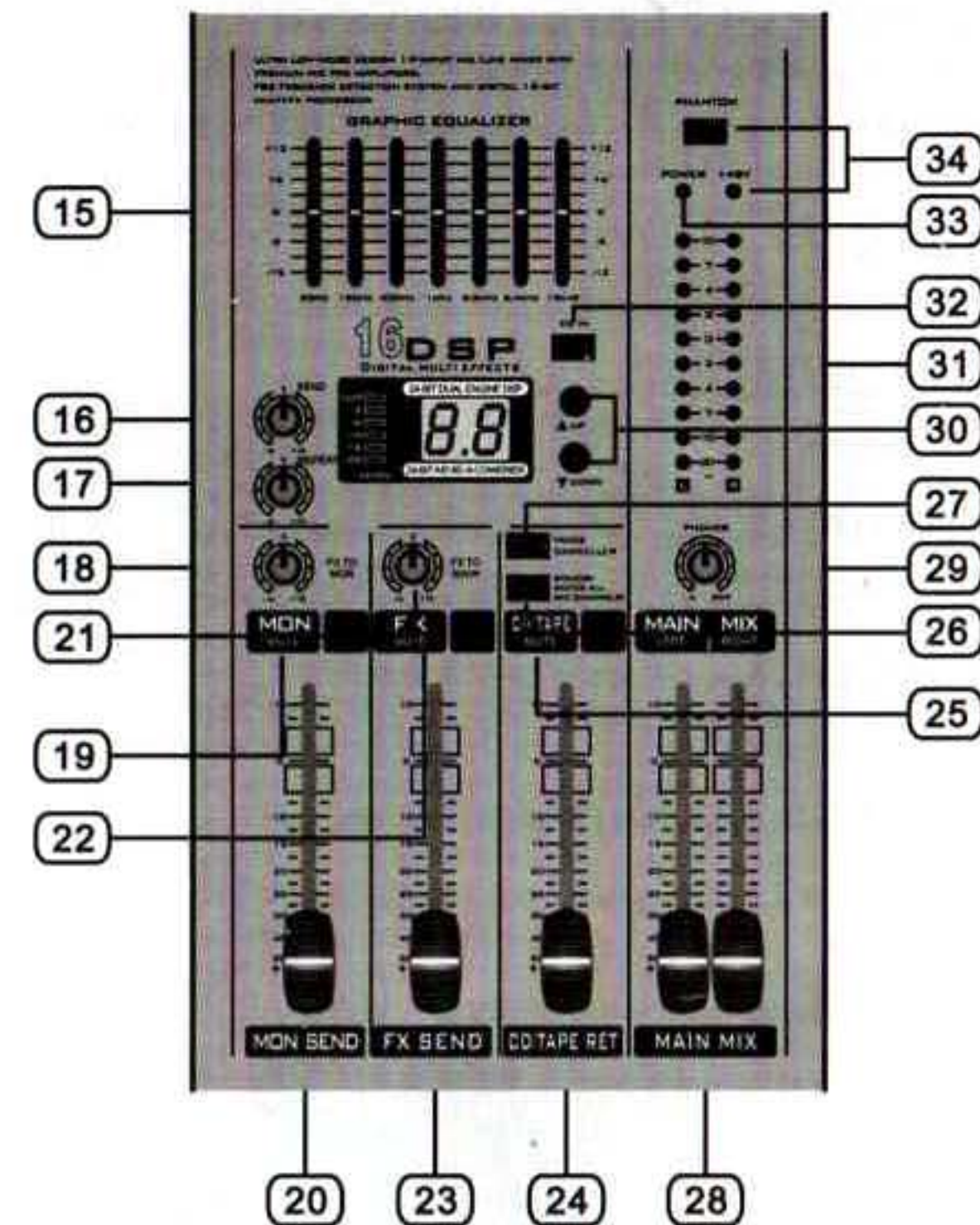

### 31.OUTPUTS LEVEL INDICATOR

This is level meter which shows output levels of left & right channel and working condition on the way of operation. Therefore, You can see output condition thru this master level indicator. The LED shows power is turned "ON" or "OFF"

### 32.EQ IN

Use this switch to activate the graphic equalizer.

### 33.POWER LED

The power LED will be turned on when start working.

### 34.PHANTOM POWER SWITCH / LED

Depressing this switch applies 48v DC across all microphone input channels connectors for remote powering of condenser microphones. The LED will be turned on when start working.

## C.MIXER OUTPUT SECTION

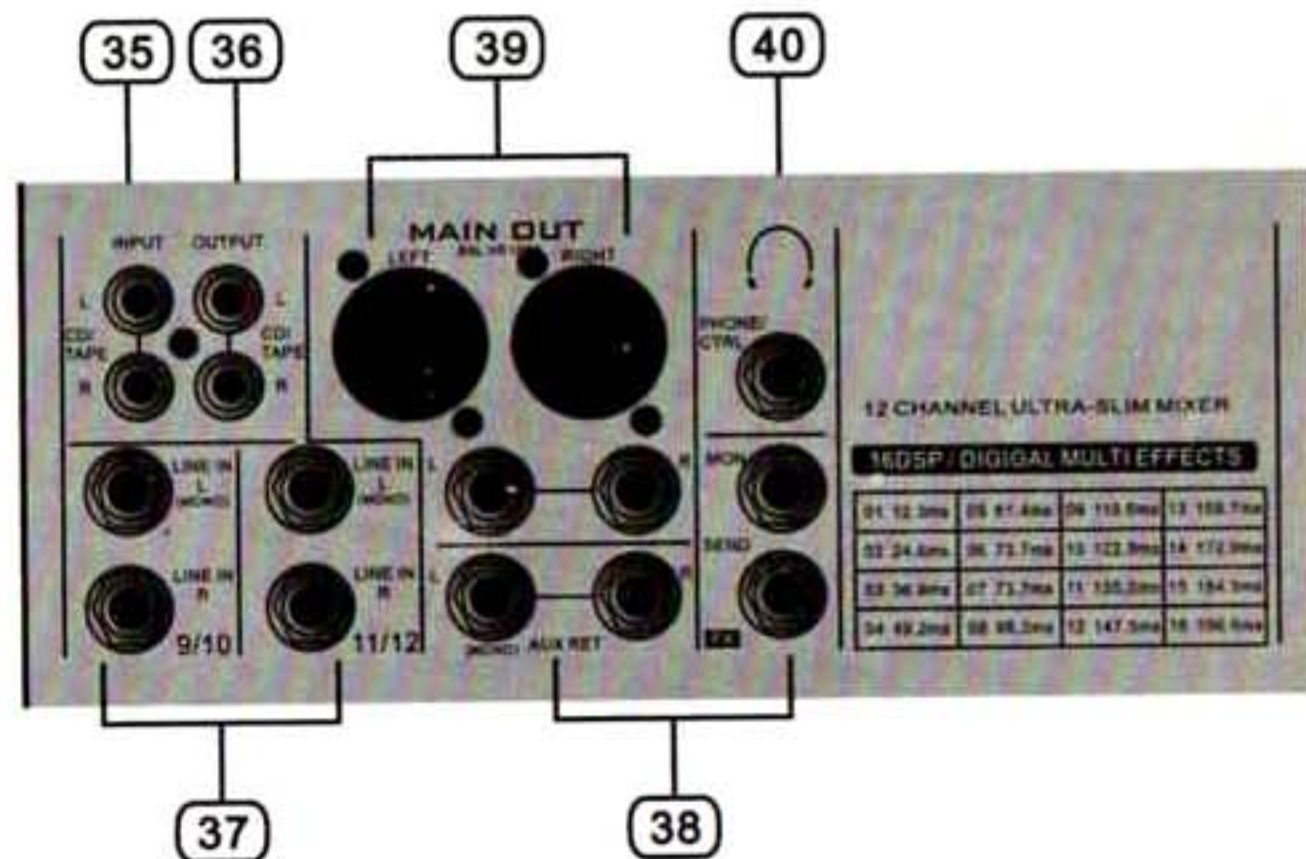

### 35.TAPE INPUT JACK

This jack is to be connected with cassette deck when playing back.

### 36.RECORD PIN JACK

This jack is to be connected with cassette deck when recording the mixed output.

### 37.LEFT(MONO) / RIGHT

Line with connection 1 / 4 jack as line input of L, R stereo and input the signal of balanced line level. If the signal input into the input terminal of left side, output the mono output to left & right side. If the signal input the input terminal of right side, output into the right side only. If each signal input the input terminal of left & right, output a stereo of left & right.

### 38.STEREO AUX RETURNS & SEND

This jack is to be connected with cassette deck when recording the mixed output.

### 39.STEREO OUTPUT JACK (LEFT/RIGHT)

In this product, the final confirmed sound can be send to main amplifier through XLR & 1 / 4 jack.

### 40.HEADPHONE JACK

You can monitor working condition by sound thru the headphone.

## D. POWER SECTION

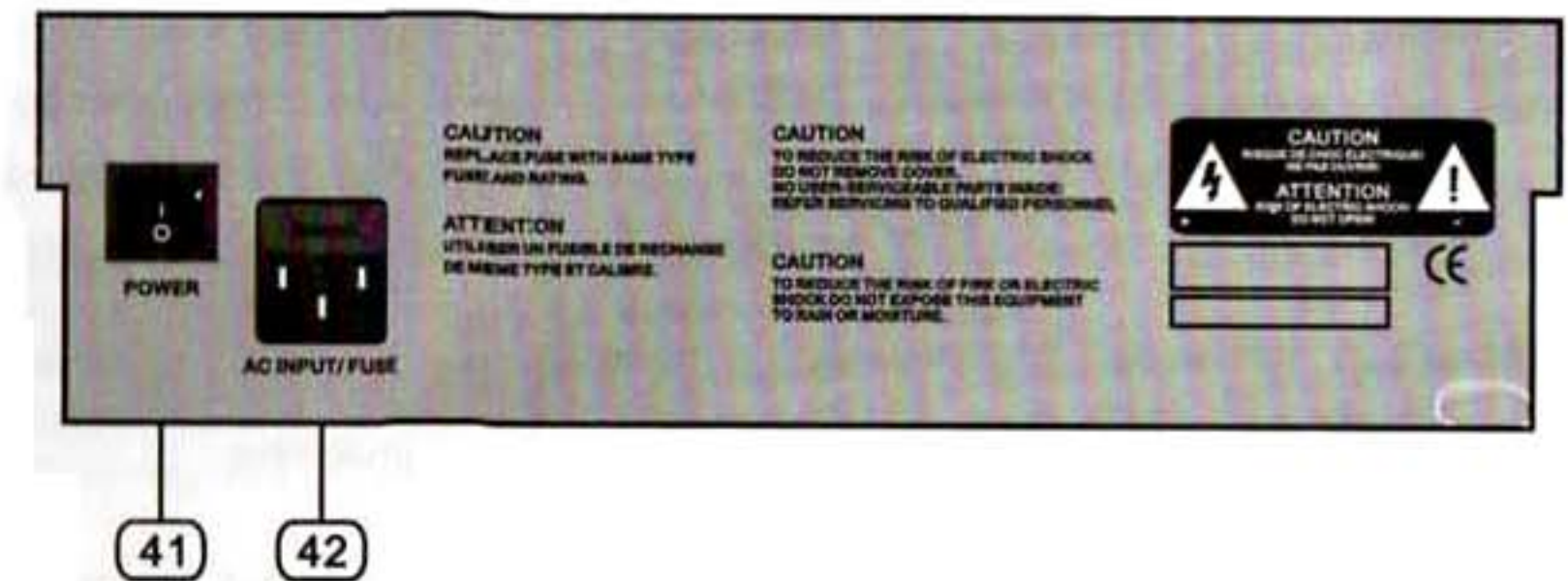

### 41.POWER SWITCH

Push marked (1). When you want to operate. The LED ( SEE Number 33) will be turned on when working

### 42.POWER JACK

This is out of connecting the power supply (2 x AC 120V or 230V) jack.

## E. INSTALLATION

Experience tells us that the cables in a studio environment get tangled very quickly (inviting mistakes).

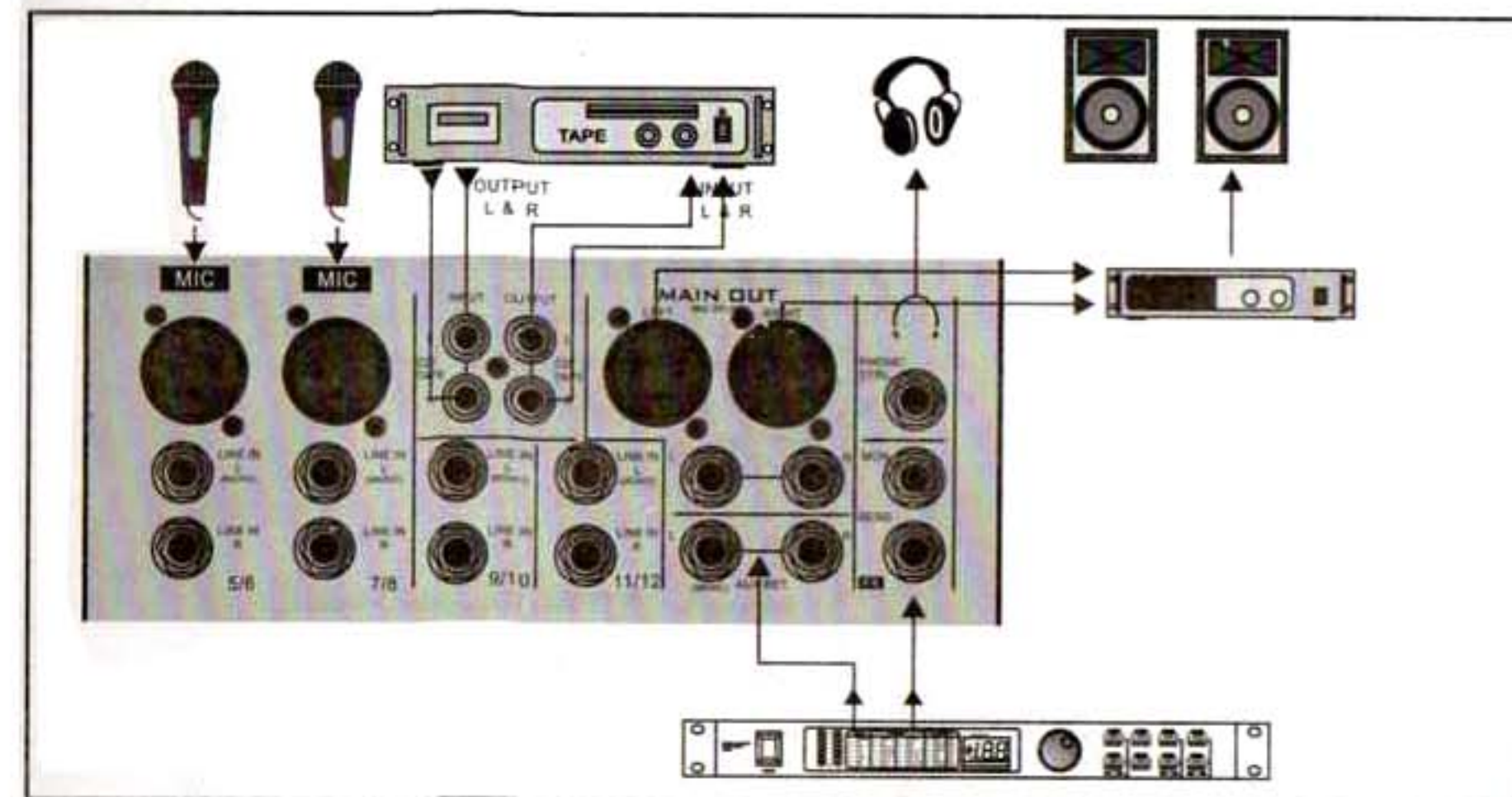

## F. HOW TO OPERATE

1. Above all, it is necessary to confirm power voltage.
2. Make sure this appliance power switch is off when connecting the plug of power cord with outlet.
3. Set every controls to the positions stated belows to avoid loud blasts. Loud blasts may course damage to for your speaker system or yout rears when you are wearing headphone.

The master faders L-R, Sub faders 1-2, Effect fader & Each channel faders.

Gain control ----- Turn to the left completely  
 Hi, Mid, Low ----- Turn to the center position  
 EFX & Effect control ----- Turn to the left completely  
 Pan control ----- Turn to the center position

### Set other turn to the left completely

4. Push power switch marked(1), then the LED will be turned on when start working.
5. Set Master faders L-R to the position between min & mid, after working.
6. Set a certain Channel faders which you want to use to the position between min & mid. After that, connect input section with exeternal source.
7. To make sound through external sources, turn the Gain control to the right.
8. Adjust tone controls in accordance with your taste.
9. Adjust between effect fader control towards max from min & Effect control to the right, When you want to get echo effect a certain channel. After set a certain channel, adjust Delay control & Repeat control. Then, you can get various echo effect sound.

FIGURE 5

#### UNBALANCED 1/4" PLUG

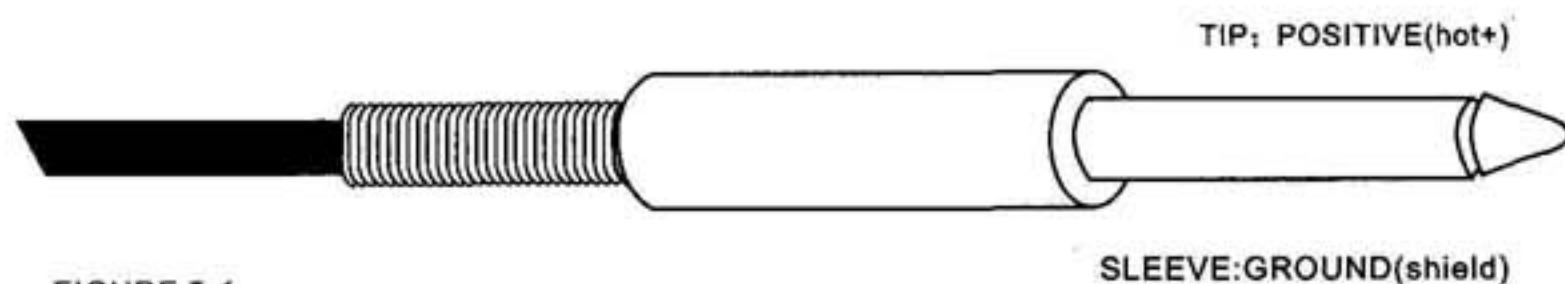

FIGURE 5-1

#### FAMALE 3 PIN CONNECTOR

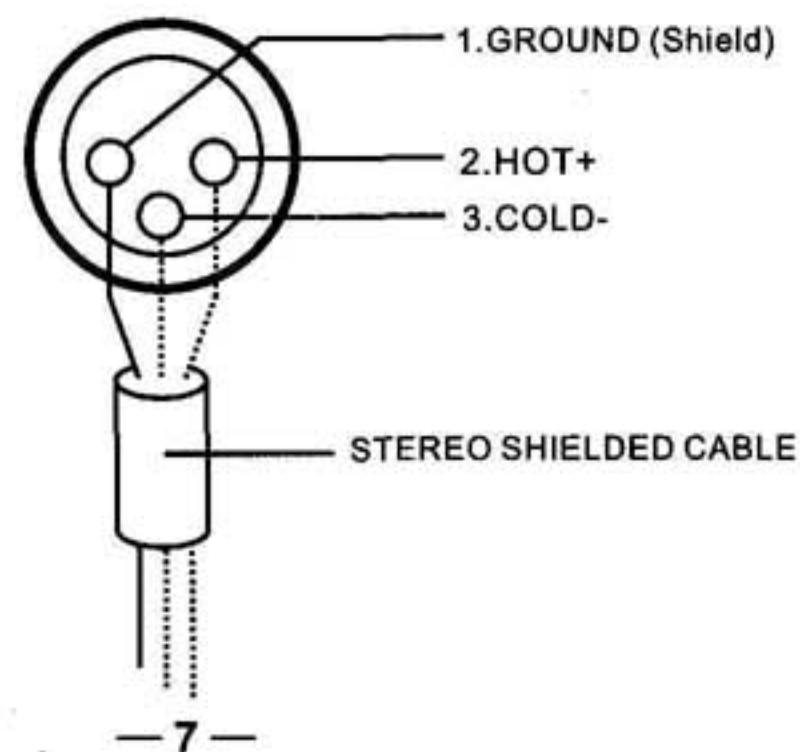

FIGURE 5-2

## G. APPENDIX SPECIFICATIONS

### Specifications

#### Mono Inputs

Mic Input B electronically balanced, discrete input configuration  
 Andwidth 10Hz to 60 kHz  $\pm 3$ dB  
 Distortion(THD&N) 0.01% at +4dBu, 1kHz, Bandwidth 80 kHz  
 Mic E.I.N(22Hz-22kHz) -129.5dBu, 150 Ohm source

-117.3dBqp, 150 Ohm source  
 -132.0dBu, input shorted  
 -122.0dBqp, input shorted  
 TRIMrange +10dB to 60dB  
 Line input electronically balanced  
 Bandwidth 10Hz to 60 KHz  $\pm 3$ dB  
 Distortion(THD&N) 0.01% at +4dBu, 1kHz, Bandwidth 80kHz  
 Line level range +10dBu to 4dBu

Equalization  
 Hi Shelving 12kHz  $\pm 15$ dB  
 Mid Range 2.5kHz  $\pm 15$ dB  
 Lo Shelving 80Hz  $\pm 15$ dB

#### Master Mix section

Max Output +22dBu balanced  
 Aux Send Max Out +22dBu unbalanced  
 Control Room Out +22 dBu unbalanced  
 Signal To Noise Ratio +112dB, all channels at Unity Gain

#### Power supply

Mains Voltages  $\sim 120$ V AC, 60Hz,  
 $\sim 240$ V AC, 50Hz,  
 $\sim 220$ V AC, 50Hz,

#### Power Supply